

+GF+ SIGNET 2754-2757 DryLoc™ pH and ORP Electrodes



Description

+GF+ SIGNET 275X DryLoc™ pH and ORP Electrodes feature a unique connector designed specifically for use with the 2750 Sensor Electronics (the robust configuration also supports the weight and torque associated with the installation and operation of integral junction boxes, and the EasyCal accessory). Rugged CPVC construction, large

reference volume and intelligent positioning of internal elements combine to extend the service-life of these dependable and highly responsive electrodes. Flat versions allow sediment and particles to sweep past the measurement surface, minimizing risks of abrasion, breakage and coating.

Technical Features

- a) Foul-proof connector with gold-plated contacts
- b) Keyed for a simple, sure fit
- c) Viton® O-rings (standard)
- d) Silicone-bushing seal
- e) Secondary junction: Nylon filament
- f) Ag/AgCl reference element
- g) Platinum sensing surface (ORP) or pH glass
- h) Primary junction: Porous UHMW polyethylene
- i) PT-1000 RTD (pH only)
- j) Solidified acrylamide reference electrolyte
- k) Ag/AgCl measuring element
- l) Large reference volume
- m) Epoxy seal
- n) Shielding
- o) 10KΩ I.D. resistor (ORP only)

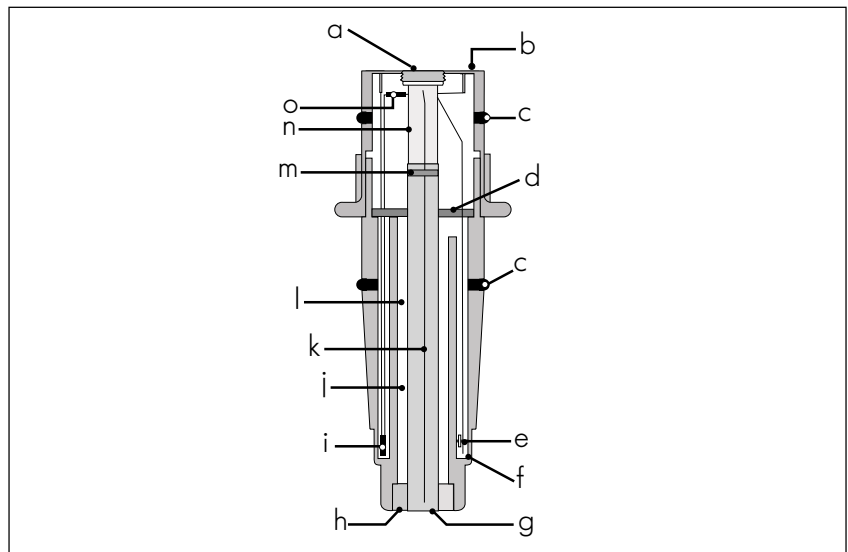

Features

- Designed for use with 2750 DryLoc™ Sensor
- Foul-proof connector
- Gold-plated contacts
- Durable CPVC body
- Self-cleaning flat versions reduce risk of glass breakage
- Large reference volume and solid polymer electrolyte
- Temperature sensor included in pH electrodes
- DI option for pure water
- HF option for pH

Applications

- Water & Wastewater Treatment
- Neutralization Systems
- Scrubber Control
- Effluent Monitoring
- Surface Finishing
- Heavy Metal Removal and Recovery
- Toxics Destruction
- Sanitization Systems
- Commercial Pools & Spas
- Aquatic Animal Life Support Systems
- Process Control

Dimensions

3-2754 Flat pH
3-2755 Flat ORP

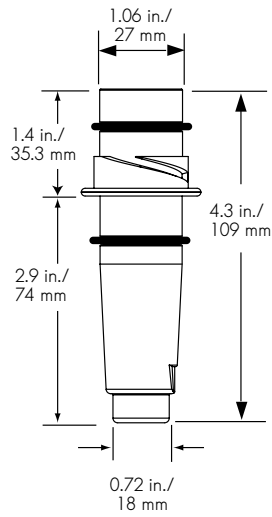

3-2756 Bulb pH
3-2757 Bulb ORP

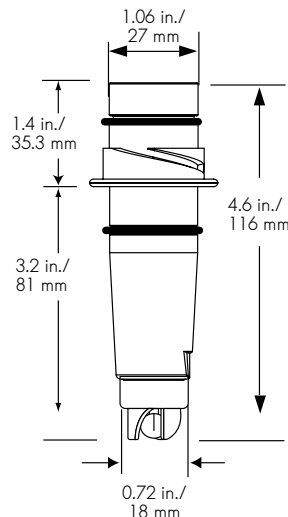

Sensor Mounting

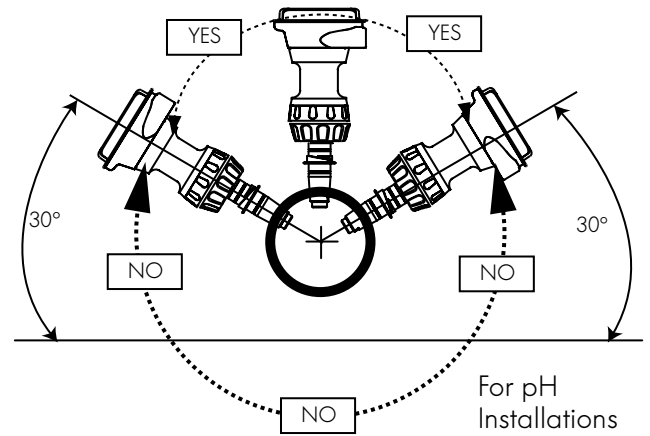

- It is recommended that you do not install standard electrodes within 30° of horizontal.
- Special electrodes for horizontal or inverted installation are available - contact factory.

Installation

In-Line Installation

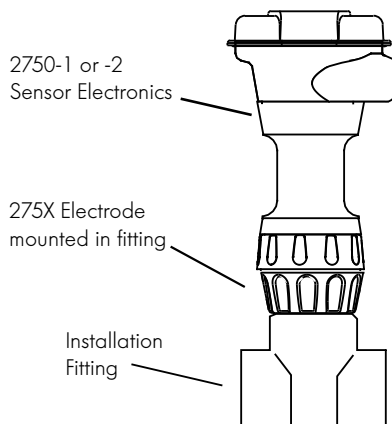

Submersible Installation

To prevent moisture accumulation at the cable-end of the pre amplifier, fill the lower 3 to 4 in. of conduit or extension pipe with a flexible sealant, such as silicone.

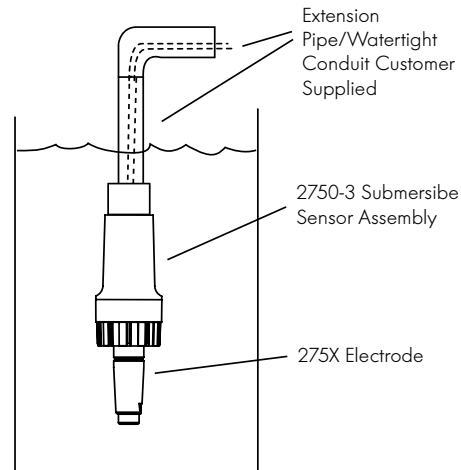

Fitting Types for In-Line Installations

Refer to Fittings section of +GF+ SIGNET catalog for a complete listing of part numbers.

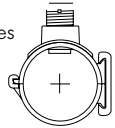
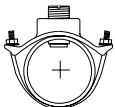
Type	Description
 Plastic tees	<ul style="list-style-type: none"> • Available in 1/2 in. to 4 in. sizes • PVC, CPVC w/solvent cement socket • PVDF and PP w/union end fittings
 PVC saddles	<ul style="list-style-type: none"> • Available in 2 in. to 4 in. sizes • Requires 1-7/16 in. hole in pipe
 Iron strap-on saddles	<ul style="list-style-type: none"> • Available in 2 in. to 4 in. sizes • Requires 1-7/16 in. hole in pipe

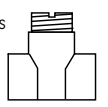
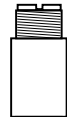
Type	Description
 Carbon steel weldolets	<ul style="list-style-type: none"> • Available in 2 in. to 4 in. sizes • Requires 1-7/16 in. hole in pipe • Install by certified welder only
 Carbon steel threaded tees	<ul style="list-style-type: none"> • Available in 1/2 in. to 2 in. sizes • Female NPT ends
 Universal pipe adapters	<ul style="list-style-type: none"> • Use for installation in pipes > 4 in. (1-1/4 in. NPT) • PVC, CPVC, or PVDF versions • Specify socket or 1-1/4 inch NPT male threads

Technical Data

2754 and 2756 pH Electrodes

Operating Range 2754, 2756:	0 to 14 pH
Operating Range 2754-HF:	0 to 12 pH
Temperature:	
2756:	0°C to 85°C (32° to 185°F)
2754:	10° to 85°C (50° to 185°F)
2754-HF:	0° to 50°C (32° to 122°F)
Storage Temperature:	> -12° C (11° F)
Pressure:	6.89 bar @ 0°C (100 psi @ 32° to 149°F) 4.00 bar @ 85°C (58 psi @ 150° to 185°F)
Pipe Size Range:	1/2 in. and up. Use +GF+SIGNET installation fittings from 0.5 to 4.0 in. (use pipe adapter in pipes over 4 in.) Vertical mounting ±60° required. Submersion with 3-2750 sensor requires 3/4 in. NPT or ISO 7-1/R 3/4 male threaded extension pipe.
Temperature Sensor:	PT-1000 (1096.8Ω @ 25°C) Response Time, τ = 140 secs. (2754), 196 secs. (2756)
Wetted Materials:	CPVC Body Glass FPM - Viton® O-rings Porous UHMW Polyethylene (Primary reference junction)
Reference:	Electrolyte: Solidified Acrylamide Gel 3.5M KCl (2754, 2754-HF, 2756) 0.1 M KCl (2756-DI) Secondary junction: Nylon filament Element: Ag/AgCl
Primary Functions:	2754: Flat surface resists fouling 2756: Bulb surface for general use 2754-HF: Extended use in applications with trace hydrofluoric acid (<2%) 2756-DI: Extended use in pure waters (< 100 μS)
Efficiency:	>97% @ 25°C (77° F)
pH Response Time:	< 5 secs. for 95% of signal change (for flat and bulb style electrodes)
Shipping Weight:	0.25 kg (0.55 lb)

2755/2757 ORP Electrodes

Operating Range:	ORP: ±2,000 mV
Operating Temperature/Pressure:	6.89 bar @ 0°C (100 psi @ 32° to 149° F) 4.00 bar @ 85°C (58 psi @ 150° to 185°F)
Storage Temperature:	> -12° C (11° F)
Pipe Size Range:	1/2 in. and up. Use +GF+ SIGNET installation fittings from 1/2 to 4 in. (use pipe adapters in pipes over 4 in.) Submersion with 3-2750 sensor requires 3/4 in. NPT or ISO 7-1 /R 3/4 in. male threaded extension pipe.
Efficiency:	> 97% @ 25°C (77 °F)
ORP Response Time:	Application dependent
Materials:	CPVC Body Glass FPM-Viton® O-rings Porous UHMW Polyethylene (Primary reference junction) Platinum sensing surface
Reference:	Electrolyte: Solidified Acrylamide Gel = 3.5M KCL Secondary junction: Nylon filament Element: Ag/AgCl
Primary Functions:	2755: Flat surface resists fouling 2757: Bulb surface for general use
Shipping Weight:	0.25 kg (0.55 lb)

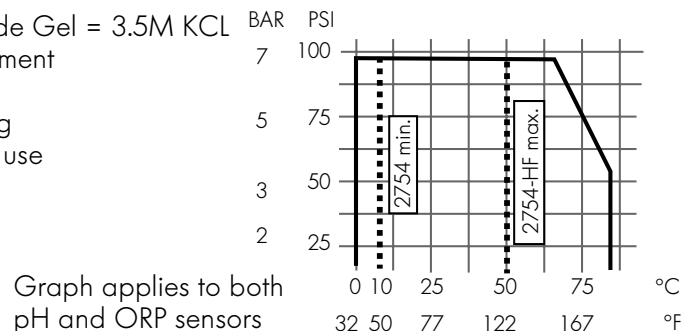

Ordering Information

Mfr. Part No.	Code	Description
3-2754	159 000 747	Flat pH Electrode
3-2754-HF	159 000 748	Flat pH Electrode, HF Resistant
3-2755	159 000 749	Flat ORP Electrode
3-2756	159 000 750	Bulb pH Electrode
3-2756-DI	159 000 751	Bulb pH Electrode, DI Resistant
3-2757	159 000 752	Bulb ORP Electrode
3-2750-1	159 000 744	In-line Sensor Electronics w/Junction Box
3-2750-2	159 000 745	In-line Sensor Electronics w/Junction Box & Local EasyCal
3-2750-3	159 000 746	Submersible Sensor Electronics

Accessories

Mfr. Part No.	Code	Description
P31515-0P200	159 000 630	Universal Pipe Adapter PVC
P31515-0C200	159 000 631	Universal Pipe Adapter CPVC
P31515-0V200	159 000 459	Universal Pipe Adapter PVDF
3-0700.390	198 864 403	pH Buffer Kit
3-2759	159 000 762	pH/ORP Simulator/System Tester
3-2759.391	159 000 764	Adapter Cable for use w/2750
1220-0021	198 801 186	O-ring, FPM (standard)
1224-0021	198 820 006	O-ring, EPR
1228-0021	198 820 007	O-ring, Kalrez®

2759 pH/ORP System Tester Specifications

- A) Power OFF Button
- B) Output simulation buttons and indicators. Simulate pH and ORP output at five fixed values: pH 4, pH 7, pH 10, -700 mV and +700 mV. Pressing one of these buttons turns the 2759 on.
- C) Low battery indicator
- D) High Ω switch: Adds 1000 M Ω resistance in series with output. Simulates high impedance of pH electrodes. Used to verify proper preamplifier operation.
- E) 3-2759.391: Adapter cable for use with 2750
- F) 3-2759.390: Bypass adapter cable (included with 2759)
- G) Mode selector switch: Trigger automatic sensor recognition software in +GF+ SIGNET pH/ORP instrumentation.

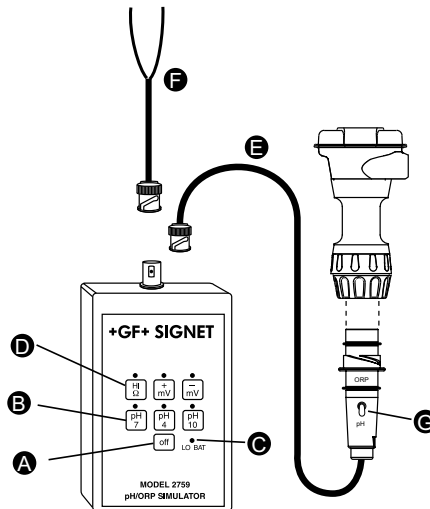

Engineering Specifications

- The electrode shall have a foul-proof connector with gold-plated contacts.
- The electrode connector shall be keyed for simple, sure connection.
- The electrode body shall be constructed of CPVC.
- The electrode shall have flat measuring glass or include guard.
- The electrode shall have solidified acrylamide, solid polymer reference electrolyte.
- The electrode shall have a double UHMW reference junction.
- The pH reference element shall be placed opposite the TC element for accurate temperature compensation.
- The electrode shall be equipped for either in-line or submersible installation using manufacturer supplied hardware.
- Optional: 3-2754-HF The electrode shall be supplied with a measuring glass formulation resistant to chemical attack from hydrofluoric acid/fluoride ions.
- The electrode shall indicate month and year of manufacture.

Kalrez® is a registered trademark of DuPont Dow Elastomers.