

## Vibration Limit Switch

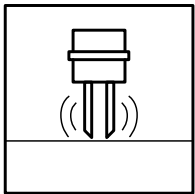

### Vibracon LVL-M NAMUR



Ü



CE

### Features

- Large selection of process connections: universal use
- Process connections from 3/4" and compact fork: also for difficult to access areas
- NAMUR signal output
- No calibration: quick, low-cost start-up
- No mechanically moving parts: no maintenance, no wear, long operating life
- Monitoring of fork for damage: guaranteed function

## Dimensions

Vibracon LVL-M with polyester housing and process connection G□□

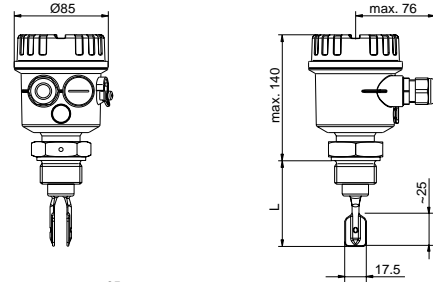

Vibracon LVL-M with aluminium housing and process connection with flange

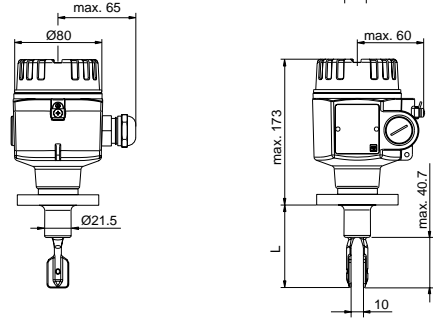

Length L see process connections

### Function

The Vibracon is a level limit switch for use in all liquids

- with a temperature between -40 °C and +150 °C
- with a pressure up to 64 bar (930 psi)
- with a viscosity up to 10000 mm<sup>2</sup>/s
- with a density from 0,5 g/cm<sup>3</sup>.

The function is not affected by flow, turbulence, bubbles, foam, vibration, bulk solids content or build-up. The Vibracon is thus the ideal replacement for float switches.

Compact design, ideal for mounting in pipes (LVL-M1).

With extension tube to 3 m (LVL-M2).

High corrosion-resistant Alloy C4 (2.4610) is available for the fork and process connections for applications in very aggressive liquids.

EEx ia (IS) and EEx d (XP) protection enable it to be used in explosion hazardous areas.

### Electrical connection

Example: connection FEL56 (N1) two-wire connection

For more connection types see chapter electrical connections.

Two-wire connection for separate switching unit

For connecting to isolated switch amplifiers acc. to NAMUR (IEC 60947-5-6), e. g. isolated switch amplifier KFD2-SR2-Ex1.W or remote process interface KSD-BI-Ex2 from Pepperl+Fuchs. Output signal jump from low to high current on limit.

(L-H edge)

Connecting to multiplexer:  
Adjust clock time to min. 2 s.

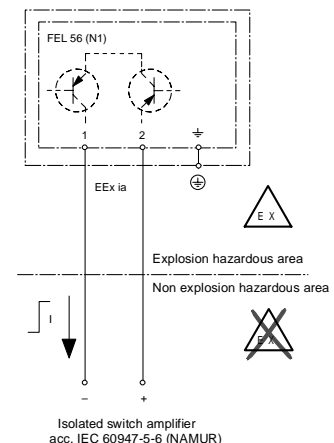

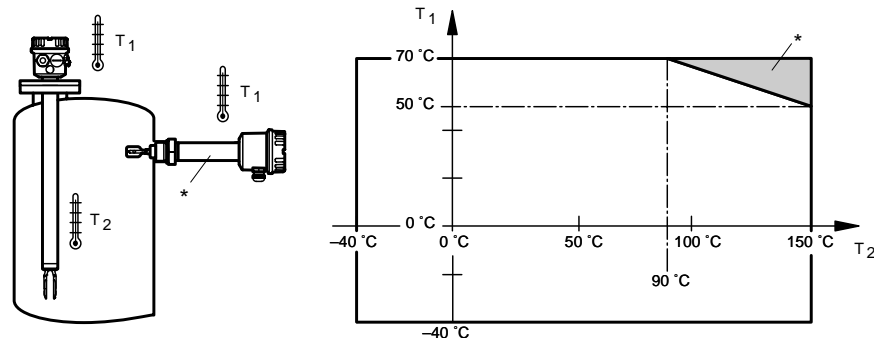
	<b>Vibracon LVL-M NAMUR</b>
<b>Application</b>	
<b>Function principle</b>	Limit detection Maximum or minimum detection in tanks or piping containing all types of liquids including use in explosion hazardous areas, food and pharmaceuticals.
<b>Function and system design</b>	
<b>Measuring principle</b>	The forks vibrate at their intrinsic frequency. This frequency is reduced when covered with liquid. The change in frequency then activates a limit switch.
<b>Input</b>	
<b>Measured variable</b>	Level (limit value)
<b>Measuring range</b>	LVL-M1: specified by mounting point LVL-M2: specified by length of sensor with extension pipe (max. 3000 mm/115 inch)
<b>Medium density</b>	Adjustment on the electronic insert > 0.5 g/cm <sup>3</sup> or > 0.7 g/cm <sup>3</sup>
<b>Output</b>	
<b>Fail-safe mode</b>	Switch-over for minimum/maximum residual current safety on electronic insert Max. = Maximum fail-safe The output switches to the power fail response when the fork is covered. For use with e. g. overspill protection Min. = Minimum fail-safe The output switches to the power fail response when the fork is free. For use with e. g. dry pump running
<b>Switching time</b>	approx. 0.5 s when fork is covered approx. 1.0 s when fork is free
<b>Power up response</b>	When switching on the power supply the output assumes the alarm signal. After max. 2 s it assumes the correct switching mode.
<b>Auxillary energy</b>	
<b>Supply voltage</b>	See technical data of isolated switch amplifier connected according to EN 50227 (NAMUR)
<b>Cable entry</b>	Electronic inserts: cable section max. 2.5 mm <sup>2</sup> , strand in cable sleeve acc. to DIN 46228 Protective earth in housing: cable section max. 2.5 mm <sup>2</sup> External terminal for plant grounding system: cable section max. 4 mm <sup>2</sup>
<b>Operating conditions</b>	
<b>Installation</b>	
Mounting position	LVL-M1: any position LVL-M2: with short pipe (up to approx. 500 mm/20 inch) any position, with long pipe vertical
<b>Environment</b>	
Ambient temperature range	-40 ... +70 °C (-40 ... +160 °F) Permissible ambient temperature T <sub>1</sub> at the housing dependent on the product temperature T <sub>2</sub> in the vessel:
	 <p>The diagram shows a cylindrical vessel with a sensor probe inserted. The probe has a fork at the bottom. The ambient temperature is labeled T<sub>1</sub> and the product temperature is labeled T<sub>2</sub>. A graph plots T<sub>1</sub> (y-axis, -40 °C to 70 °C) against T<sub>2</sub> (x-axis, -40 °C to 150 °C). The graph shows a horizontal line at T<sub>1</sub> = 70 °C for T<sub>2</sub> up to 90 °C. For T<sub>2</sub> &gt; 90 °C, the permissible T<sub>1</sub> decreases linearly from 70 °C to 50 °C at T<sub>2</sub> = 150 °C. A shaded area labeled with an asterisk (*) is shown above the 50 °C line for T<sub>2</sub> &gt; 90 °C, indicating an additional temperature range for sensors with a temperature spacer or pressure-tight bushing.</p>
	* additional temperature range for sensors with a temperature spacer or pressure-tight bushing
Ambient temperature limit	-50 ... +70 °C (-60 ... +160 °F), (function with reduced data values)
Storage temperature	-50 ... +80 °C (-60 ... +180 °F)
Climate class	Climatic protection to IEC 68, part 2-38, fig. 2a
Degree of protection	DIN EN 60529, IP66/67
Vibration resistance	acc. to IEC 68, part 2-6 (10 ... 55 Hz, 0.15 mm, 100 cycles)
Electromagnetic compatibility	Interference emission acc. to EN 61326-1, EN 50081-1 Interference immunity acc. to EN 61326-1 (industrial use), EN 50082-2 (1995)
<b>Process</b>	
Process temperature range	-40 ... +150 °C (-40 ... +300 °F), for exceptions see process conditions
Process pressure	-1 ... +64 bar (-14.5 ... 930 psi) over the entire temperature range, for exceptions see process connections
Process pressure limit	Burst pressure of diaphragm 200 bar (2900 psi)
Thermal shock resistance	max. 120 °C/s (max. 250 °F/s)
State of aggregation	liquid
Density	min. 0.5 g/cm <sup>3</sup>

Date of issue 04.02.2002

**Vibracon LVL-M NAMUR**

Viscosity max. 10000 mm<sup>2</sup>/s (max. 10000 cSt)  
Bulk solids content max. Ø5 mm (0.2 inch)

**Mechanical construction**

**Design**

LVL-M1: Compact design  
LVL-M2: Design with extension pipe

**Dimensions**

Housing: diameter max. 85 mm (3.3 inch), height max. 173 mm (6.8 inch), exsample

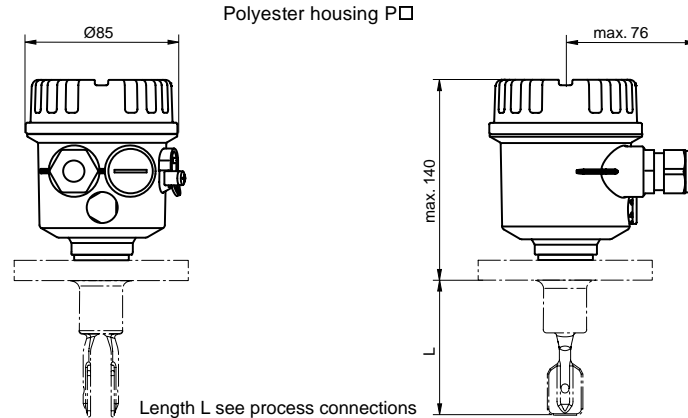

Temperature spacer, pressure-tight bushing: additional length L 140 mm (5.5 inch)

Process connections: length L 66.5 ... 69 mm (2.6 ... 2.7 inch)

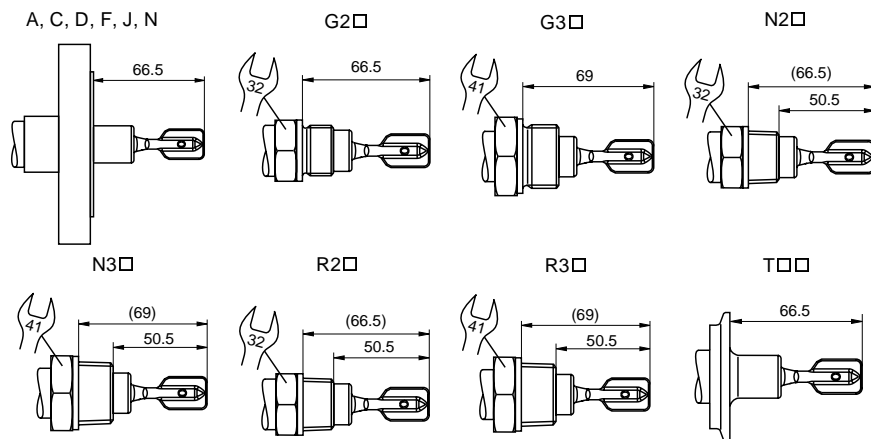

With extension pipe: any length L from 148 ... 3000 mm (6 ... 115 inch), dependent on process connection

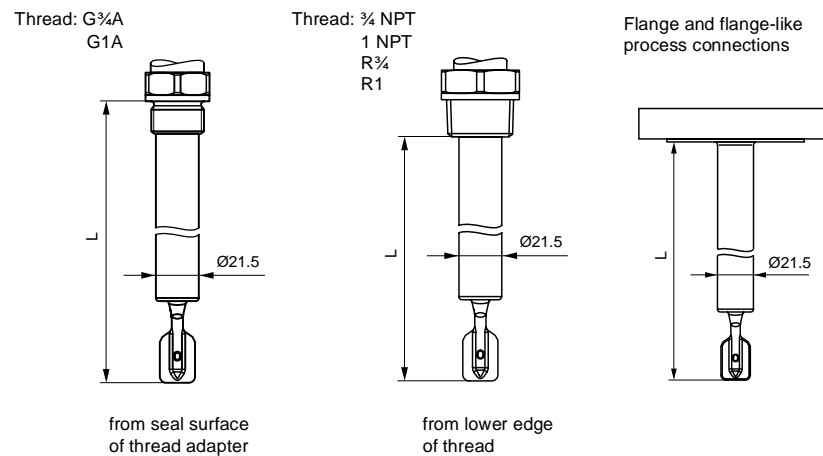

With extension pipe length II: with vertical mounting from above the same switchpoint as for the Vibracon LVL1, LVL2

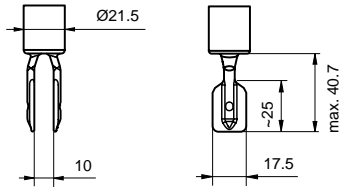
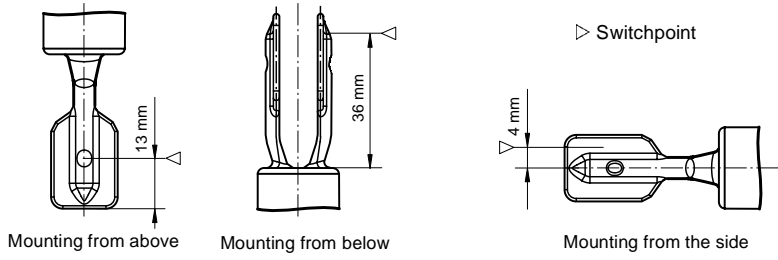
	<p><b>Vibracon LVL-M NAMUR</b></p> <p>Vibration fork: breadth 17,5 mm (0.7 inch), width of fork 10 mm (0,4 inch), max. length 40.7 mm (1.7 inch)</p> 																								
<p><b>Weight</b></p>	<p>600 g, basic weight: includes compact sensor, BSP<math>\frac{3}{4}</math> (G<math>\frac{3}{4}</math>A) thread adapter, electronic insert, stainless steel housing</p>																								
<p><b>Switch point</b></p>	<p>Switchpoints on the sensor depend on the mounting position, with reference to water, density 1 g/cm<sup>3</sup>, 23 °C, p<sub>e</sub> 0 bar.</p>  <p><b>Note:</b> The switchpoints of the Vibracon LVL-M1, LVL-M2 are at other positions to those of the previous version LVL1, LVL2.</p>																								
<p><b>Human interface</b></p>																									
<p><b>Display elements</b></p>	<p>Electronic insert FEL 56 (N1):</p> <ul style="list-style-type: none"> <li>• green LED flashes to indicate power on</li> <li>• red LED to indicate switching status, flashes on damage by corrosion on sensor or with defective electronics</li> </ul> <p>Electronic insert FEL 58 (N2):</p> <ul style="list-style-type: none"> <li>• green LED flashes rapidly to indicate power on</li> <li>• green LED flashes slowly on damage by corrosion on sensor or with defective electronics</li> <li>• yellow LED to indicate switching status</li> <li>• Test key – breaks the cable connection</li> </ul>																								
<p><b>Operating elements</b></p>	<p>2 switches for fail-safe mode and density change</p>																								
<p><b>Zertificates and approvals</b></p>																									
<p><b>Ex approval</b></p>	<p>see type code</p>																								
<p><b>Type of protection</b></p>	<p>see type code</p>																								
<p><b>Overspill protection</b></p>	<p>Z-65.11-306 (Wasserhaushaltsgesetz WHG)</p>																								
<p><b>General informations</b></p>																									
<p><b>Standard conformity</b></p>	<p>all products: EN 61010-1, EN 61326 selected products:</p> <table border="0" data-bbox="566 1512 1492 1724"> <tr> <td>KEMA 01 ATEX 2117</td> <td>KEMA 01 ATEX 1089</td> <td>KEMA 01 ATEX 1147 X</td> </tr> <tr> <td>EN 61326</td> <td>EN 61326</td> <td>EN 61326-1</td> </tr> <tr> <td>EN 61010-1</td> <td>EN 61010-1</td> <td>EN 50081-1</td> </tr> <tr> <td>EN 50014</td> <td>EN 50014</td> <td>EN 50082-1</td> </tr> <tr> <td>EN 50020</td> <td>EN 50020</td> <td>EN 61010-1</td> </tr> <tr> <td>EN 50284</td> <td>EN 50284</td> <td>EN 50014</td> </tr> <tr> <td></td> <td></td> <td>EN 50020</td> </tr> <tr> <td></td> <td></td> <td>EN 50284</td> </tr> </table>	KEMA 01 ATEX 2117	KEMA 01 ATEX 1089	KEMA 01 ATEX 1147 X	EN 61326	EN 61326	EN 61326-1	EN 61010-1	EN 61010-1	EN 50081-1	EN 50014	EN 50014	EN 50082-1	EN 50020	EN 50020	EN 61010-1	EN 50284	EN 50284	EN 50014			EN 50020			EN 50284
KEMA 01 ATEX 2117	KEMA 01 ATEX 1089	KEMA 01 ATEX 1147 X																							
EN 61326	EN 61326	EN 61326-1																							
EN 61010-1	EN 61010-1	EN 50081-1																							
EN 50014	EN 50014	EN 50082-1																							
EN 50020	EN 50020	EN 61010-1																							
EN 50284	EN 50284	EN 50014																							
		EN 50020																							
		EN 50284																							
<p><b>Supplementary informations</b></p>	<p>www.pepperl-fuchs.com</p>																								
<p><b>Accessories</b></p>																									
<p><b>Designation</b></p>	<ul style="list-style-type: none"> <li>• LVL-Z100, welded sleeve G<math>\frac{3}{4}</math></li> <li>• LVL-Z101, welded sleeve G1</li> <li>• LVL-Z120, sliding sleeve for unpressurised operation G1A</li> <li>• LVL-Z121, sliding sleeve for unpressurised operation G1<math>\frac{1}{2}</math>A</li> <li>• LVL-Z124, high pressure sliding sleeve G1A</li> <li>• LVL-Z126, high pressure sliding sleeve G1<math>\frac{1}{2}</math>A</li> </ul>																								

Electrical connection

• Connection FEL 56 (N1)

Two-wire connection for separate switching unit

For connecting to isolated switch amplifiers acc. to NAMUR (IEC 60947-5-6), e. g. isolated switch amplifier KFD2-SR2-Ex1.W or remote process interface KSD-BI-Ex2 from Pepperl+Fuchs. Output signal jump from low to high current on limit.

**(L-H edge)**

Connecting to multiplexer:  
Adjust clock time to min. 2 s.

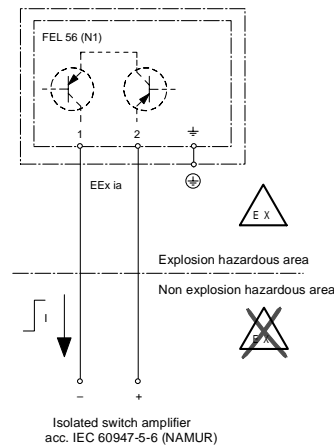

• Connection FEL 58 (N2)

Two-wire connection for separate switching unit

For connecting to isolated switch amplifiers acc. to NAMUR (IEC 60947-5-6), e. g. isolated switch amplifier KFD2-SR2-Ex1.W or remote process interface KSD-BI-Ex2 from Pepperl+Fuchs. Output signal jump from high to low current on limit.

**(H-L edge)**

Additional function: Test key on the electronic insert. Pressing the key breaks the connection to the isolated switch amplifier.

Note: The test function can be used for EEx d applications provided that no explosive atmosphere is present near to the housing.

Connecting to multiplexer:  
Adjust clock time to min. 2 s.

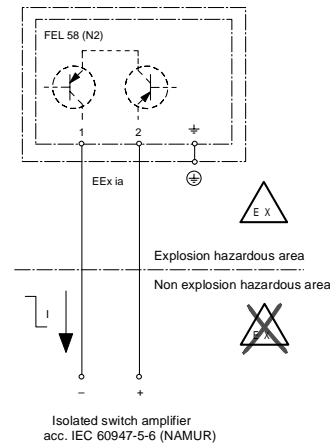

Type code/ordering code



- Length without size unit for design M2
- Certificates and approvals**
- NA** Version for non explosion hazardous area
  - WH** Overspill protection to WHG (Germany)
  - E2** II 1/2G, EEx ia IIC T6, overspill protection to WHG (Germany)
  - E3** II 1/2G, EE xd IIC T6
  - EC** II 1/2G, EE xd IIC T6, overspill protection to WHG (Germany)
  - FI** FM IS C1 I,II,III Div1 Group A-G
  - CI** CSA IS C1 I,II,III Div1 Group A-G
  - CG** CSA General purpose
- Additional fittings**
- NA** Basic fittings
  - Z3** 3.1.B certificate (German) for wetted parts material 1.4435/316L; inspection certificate to EN 10204, according to specification 52005759
- Electrical output**
- N1** FEL 56, NAMUR, L-H edge
  - N2** FEL 58, NAMUR with test key, H-L edge
- Housing; cable entry**
- A1** Aluminium housing, IP66, cable gland M20
  - A4** Aluminium housing, IP66, connector M12 x 1
  - E1** Stainless steel housing (1.4301/304L), IP66, cable gland M20
  - E4** Stainless steel housing (1.4301/304L), IP66, connector M12 x 1
  - P1** Polyester housing, IP66, cable gland M20
  - P4** Polyester housing, IP66, connector M12 x 1
- Length, temperature spacer, pressure-tight bushing**
- Design M1 **AA** compact design, Ra < 3.2 µm/80 grit
  - Design M1 **IA** 66 mm/2.6", with temperature spacer
  - Design M2 **BB** mm L 1.4435/316L, Ra < 3.2 µm
  - Design M2 **BE** mm L Alloy C4/2.4610, Ra < 3.2 µm
  - Design M2 **DB** Length II, 1.4435/316L, Ra < 3.2 µm, switchpoint = Vibracon compact
  - Design M2 **DE** Length II, Alloy C4/2.4610, Ra < 3.2 µm, switchpoint = Vibracon compact
  - Design M2 **JB** mm L 1.4435/316L, with temperature spacer
  - Design M2 **JE** mm L Alloy C4/2.4610, with temperature spacer
  - Design M2 **LB** Length II, 1.4435/316L, with temperature spacer
  - Design M2 **LE** Length II, Alloy C4/2.4610, with temperature spacer, switchpoint = Vibracon compact
- Process connection, material**
- A31** ANSI 1" 150 lbs RF, 1.4435/316L
  - A41** ANSI 1½" 150 lbs RF, 1.4435/316L
  - A51** ANSI 1¾" 150 lbs RF, 1.4435/316L
  - A61** ANSI 2" 150 lbs RF, 1.4435/316L
  - A6C** ANSI 2" 150 lbs RF, with Alloy C4/2.4610 plating
  - A81** ANSI 3" 150 lbs RF, 1.4435/316L
  - F55** DN32 PN40 form B, 1.4435/316L
  - F65** DN40 PN40 form B, 1.4435/316L
  - F75** DN50 PN40 form B, 1.4435/316L
  - F85** DN65 PN40 form B, 1.4435/316L
  - F95** DN80 PN40 form B, 1.4435/316L
  - FA5** DN100 PN40 form B, 1.4435/316L
  - D51** DN32 PN6 form C, 1.4435/316L, with sealing bar
  - C51** DN32 PN6 form C, with Alloy C4/2.4610 plating
  - D71** DN50 PN6 form C, 1.4435/316L, with sealing bar
  - C71** DN50 PN6 form C, with Alloy C4/2.4610 plating
  - D95** DN80 PN40 form C, 1.4435/316L, with sealing bar
  - C95** DN80 PN40 form C, with Alloy C4/2.4610 plating
  - DA3** DN100 PN16 form C, 1.4435/316L, with sealing bar
  - CA3** DN100 PN16 form C, with Alloy C4/2.4610 plating
  - N21** ¾ NPT, 1.4435/316L
  - N2C** ¾ NPT, Alloy C4/2.4610
  - N31** 1 NPT, 1.4435/316L
  - N3C** 1 NPT, Alloy C4/2.4610
  - G21** BSP¾ (G¾), 1.4435/316L
  - G2C** BSP¾ (G¾), Alloy C4/2.4610
  - G31** BSP1 (G1), 1.4435/316L
  - G3C** BSP1 (G1), Alloy C4/2.4610
  - G3E** BSP1 (G1), 1.4435/316L, mounted with welded sleeve
  - T51** 1½" Triclamp ISO 2852 1.4435/316L
  - T61** 2" Triclamp ISO 2852 1.4435/316L
  - XXX** other process connections
- Design**
- M1** Compact design
  - M2** Design with extension pipe (148 mm/6 inch ... 3000 mm/115 inch)